

**SEEDS Solar Vehicle**

**Soroush Seif**

**Mahshid Hashemi**

**Tianya Shao**

**Lewis Chan**

**University of British Columbia**

**EGEN 430**

**April 2012**

*Disclaimer: "UBC SEEDS provides students with the opportunity to share the findings of their studies, as well as their opinions, conclusions and recommendations with the UBC community. The reader should bear in mind that this is a student project/report and is not an official document of UBC. Furthermore readers should bear in mind that these reports may not reflect the current status of activities at UBC. We urge you to contact the research persons mentioned in a report or the SEEDS Coordinator about the current status of the subject matter of a project/report".*



# IGEN 430: Final Report

SEEDS SOLAR VEHICLE

Soroush Seif, Mahshid Hashemi, Tianya Shao, Lewis Chan

University of British Columbia

## Executive Summary

This report will provide an overview of the SEEDS Solar Vehicle project. Background information, objectives, initial designs, deviations from the initial design, project feasibility, testing, and the results will all be presented through this report.

The project was initially proposed by UBC SEEDS (Social Ecological Economic Development Studies) “Program [that] unites campus operations and academics to advance the university’s commitment to sustainability and enhance UBC’s reputation as a sustainability leader.” The objective of this project was to design a solar tracking system that could be used in conjunction with any solar panel, and could be installed on UBC’s electric vehicles as a supplementary energy source to mains electricity. The aim of this project is to reduce UBC’s dependency on mains electricity and minimizing carbon footprint by reducing fossil fuel energy sources consumption.

A solar tracking system will be designed to increase the energy conversion efficiency of the solar panels. Research on solar tracking systems has shown promising results by increasing the efficiency of the panels by 30-50% for a given area versus modules with a fixed angle. The group has proposed a number of different tracking systems and the most efficient design with lowest power consuming components has been selected. Our first concept involved using two servos and an Arduino for the 2-axis solar tracking. Low speed, and the panel’s weight encouraged more design analysis. In order to maximize the speed and power of the system, linear actuators were selected. This design involved four linear actuators working as the main components of the system. However, preliminary calculations suggested a large amount of power required to run these actuators. In order to overcome this issue and minimize the power required to run the system, we have modified our design. In this final design a predefined optimum angle will be selected based on the month of the year. A vertical rotational axis will be employed to track the sun. This design also enables drivers to flatten the solar panels to enter the underground parking for maintenance purposes. This potential couldn’t be reached with the previous designs.

The CAD drawings of the final design were submitted to the shop and the manufacturing of all the designed components has been completed, received and assembled. We have simultaneously worked on the programming part of this project and have successfully completed this task. The solar tracking circuit that includes all the switches, light sensors, and programmed chip has been developed and testing has been performed.

The aim of this project is to minimize UBC's carbon footprint and minimize the environmental impact of electric cars by using renewable energy sources to charge the batteries on these cars. It is illogical to employ this device without thinking of the environmental impact of the raw materials used. Recyclable metal was used in the construction of the frame and for the rest of the components. Priority will be given to products made out of recyclable materials. Solar panels will remain under usage by UBC car fleet or will be reused for researching purposes.

# Table of Contents

<b>Executive Summary</b> .....	<b>2</b>
<b>Introduction</b> .....	<b>2</b>
<b>Background</b> .....	<b>3</b>
<b>Objective</b> .....	<b>3</b>
<b>Project Scope</b> .....	<b>4</b>
<b>Feasibility</b> .....	<b>5</b>
<b>Cost</b> .....	<b>6</b>
<b>Progress to Date</b> .....	<b>6</b>
Field Research .....	6
Encountered Problems .....	7
<i>Energy Consumption of Initial Design</i> .....	7
<i>Waterproofing Issue</i> .....	7
Evaluation of Design Objectives .....	7
Final Design .....	8
Circuit Design.....	8
Deviation from Proposal .....	9
<b>Methodology</b> .....	<b>11</b>
Energy Consumption.....	11
Design Dimensions .....	11
Adaptable Design .....	11
Mountable and Waterproof.....	11
Vibration.....	12
<b>Perceived Problem Areas</b> .....	<b>12</b>
Cost vs. Performance.....	12
Gears & Motor.....	12
Extra Weight .....	12
<b>Testing</b> .....	<b>12</b>
<b>Deliverables</b> .....	<b>13</b>
<b>Results</b> .....	<b>13</b>
Electricity Cost - Table 1 .....	13
Tracking - Table 2.....	14
Stationary - Table 3.....	14
CO2 Emission - Table 4.....	15
<b>Future Recommendation</b> .....	<b>16</b>
Precise System Control.....	16
<b>Gantt Chart</b> .....	<b>17</b>
<b>Conclusion</b> .....	<b>19</b>

<b>Appendix A – Calculations .....</b>	<b>20</b>
A.1 - Basic Calculations.....	20
A.2 - Solar Intensity.....	20
A.3 – Wind Resistance.....	20
A.4 – Motor Selection.....	21
<b>Appendix B – Figures &amp; Sketches.....</b>	<b>22</b>
Figure B1 - CAD model indicating main parts .....	22
Figure B2 - Diagram of the internal layout of the gearbox.....	22
Figure B3 - CAD model showing internal detail of the gearbox .....	23
Figure B5 - Initial sketch of Final Design .....	25

## Introduction

Now-a-days, the world is facing enormous climate changes due to human activity. Electricity production based on the use of non-renewable resources is one of the most impactful human activities on the earth. Electricity generation is mainly sustained by fossil fuels such as oil, coal and natural gas. Studies show that the amount of available fossil fuels will diminish by the end of this century<sup>1</sup>. Although nuclear energy has been thought to be a replacement for fossil fuels for a long time, solar energy has proven to be an extremely viable way of providing energy<sup>2</sup>. Most of the solar panels have a fixed position at a certain angle towards the sky; thus, the power output from the photovoltaic cells (PV) is greatly decreased as the intensity of solar radiation upon the solar panels varies during the day. In order to maximize the photovoltaic cell's power output, light sensors are to be used to detect the angle of maximum solar radiation. Solar panels are to be integrated with this solar tracking system which will move the panels in such a way that direct sunlight is always incident with the PV cells to ensure maximum power output.

This proposal is for a SEEDS Solar Vehicle system, which is basically to augment the electric power used to charge UBC's Building Operation electric vehicles. A few years ago, it was decided that the educational institution must be carbon free by the end of year 2010. UBC pays 2 to 3 million dollars in carbon taxes every year, so our aim is to help reduce this figure. UBC is also known as a leader in sustainability, so our project will move UBC towards its own goals. The objective of this project is to design and manufacture an automated solar panel frame that can move with the direction of sunlight, and will be mounted on top of UBC's electric vehicles to charge their batteries using the solar energy.

---

<sup>1</sup> Nader Barsoum, & Pandian Vasant. (2010). **SIMPLIFIED SOLAR TRACKING PROTOTYPE**. *Global Journal of Technology and Optimization*, 1, 38.

<sup>2</sup> Singthong Pattanasethanon. (2010). **The solar tracking system by using digital solar position sensor**. *American Journal of Engineering and Applied Sciences*, 3(4), 678-682.

## Background

UBC Social Ecological Economic Development Studies (SEEDS) program is Western Canada's first academic program that combines the expertise and commitment of staff, the academic and research experience of faculty, and the energy and enthusiasm of students to integrate sustainability on campus. It oversees projects covering everything from climate change, energy conservation, and waste management. As the sustainability leader in British Columbia, SEEDS now has a fleet of 20 electrical powered vehicles to help reduce greenhouse gas emission. However, UBC SEEDS is not only aiming at greenhouse gas emission reduction, but also energy conservation to enhance its reputation as the sustainability leader worldwide. Thus, SEEDS proposed the Solar Vehicle project in the fall 2011.

In this project, we are aiming to reduce the dependency of UBC's electric vehicles on the mains electricity by implementing solar panels. As a result, we have conducted research into the amount of solar intensity we received from the sun. The solar constant is the amount of solar energy that reaches the earth's upper atmosphere and is equal to  $1367.7 \text{ W/m}^2$ <sup>3</sup>. Some factors that affect the solar constant are: cloud cover, air pollution, location and time of the year that it is measured. In Canada, solar intensity varies from 900 to  $1,050 \text{ W/m}^2$ ; however, the peak is at solar noon when the sun is due south. The total power received from sun by earth is  $1.742 \times 10^{17} \text{ W}$  (refer to Appendix A...).

## Objective

The objective of this project is to reduce UBC's electric car fleet's dependency on the mains electricity by designing a solar tracking system that will be mounted on the rooftop of these cars.

In 2009, UBC launched an intensive climate action plan to become a net positive energy producer by 2050. UBC plans to reduce its carbon emission and go beyond carbon neutral through aggressive conservation, deployment of renewable technologies, and by

---

<sup>3</sup> <http://www.eumetcal.org/euromet/english/satmet/s2710/s2710004.htm>



re-designing its current technologies. As part of this plan, UBC is sponsoring projects related to sustainability that would help UBC reach its carbon neutral goal.<sup>4</sup>

The SEEDS Solar Vehicle project would help UBC to reduce some percentage of its electricity usage by providing an alternative energy solution to UBC's electric cars. A tracking solar panel system will be designed and manufactured to be installed on these electric cars to constantly charge the 12V batteries running the cars throughout the day.

## **Project Scope**

### **PROJECT OBJECTIVE**

To reduce UBC's electric cars fleet dependency on mains electricity by designing a solar tracking system that could be used as an alternative energy solution to charge the batteries on these cars.

### **DELIVERABLES**

- A working solar tracking prototype that could be used with any type of solar panel
- Testing results
- Recommendations

### **MILESTONES**

1. Project Proposal - 10/21/11
2. Initial Design - 12/02/11
3. Final Design - 01/06/12
4. CAD Drawings - 02/01/12
5. Testing - 03/23/12
6. Prototype - 03/03/12

### **TECHNICAL REQUIREMENTS**

1. High Efficiency - Low power consuming components
2. Adjustable height - Low height clearance maintenance bays
3. Universal Mount - Could be used with any solar panel
4. Water resistance - Seals and O-Rings
5. Wind resistance - Thrust bearing

---

<sup>4</sup> <http://www.sustain.ubc.ca/climate-action>

## Feasibility

Most people falsely think that Vancouver is not a good place for using solar energy because of its cloudy weather. The solar energy comes from light generated by the sun, rather than from direct sunlight. According to Environment Canada Climate Weather office, people in B.C. enjoy an average of 2,000 hours of sunshine every year. This might not be the highest amount of sunshine in the world, but it is definitely more than Germany and China, the two leading countries in solar hot water. In Canada, there is enough solar energy to generate an average of 2500 kWh of energy per year, which is a lot more than people think. In the southern regions of B.C. such as Vancouver, people enjoy roughly 2,100 hours of sunshine throughout the year. “As shown in the figure, the average daily solar potential in Vancouver is only slightly less than that of Miami, Florida. While Miami shows greater consistency of solar potential from month to month, Vancouver has greater seasonal extremes. Taken across a whole year Vancouver’s annual daily average solar energy production is only 8% less than Miami.”<sup>5</sup>

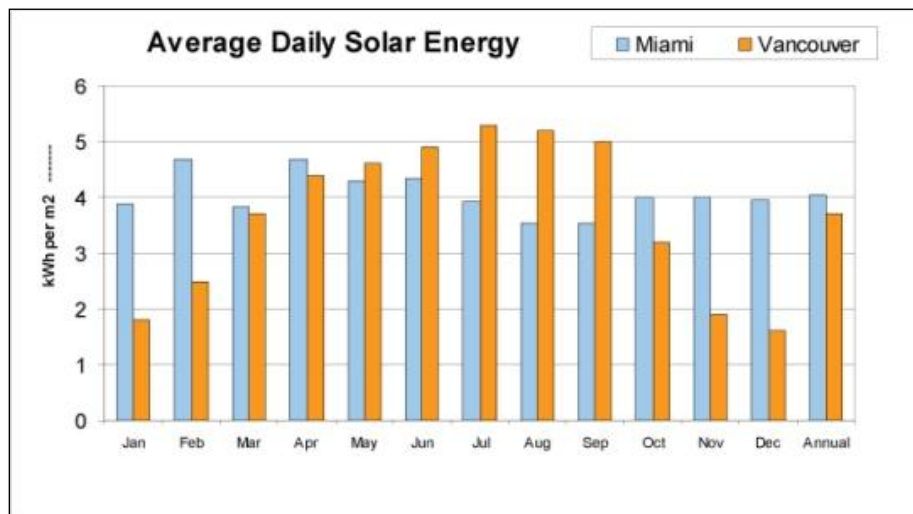

**Figure 1- Average Daily Solar Energy Comparison<sup>6</sup>**

<sup>5</sup> <http://www.solarbc.ca/learn/solar-in-bcs-climate>

<sup>6</sup> <http://www.solarbc.ca/learn/solar-in-bcs-climate>

## Cost

The initial budget of \$500 was allocated to this project by UBC Integrated Engineering Department. From this budget it was clear that no high power solar panel could be purchased. We have been fortunate to have Mark Daigle, UBC Building Operations Architectural Systems Manager, sponsoring this project and he provided us with an 110W Carmanah Solar panel. UBC Material Shop has also manufactured all the mechanical parts of this tracking unit at no cost. Our sponsor VANGEAR has also provided the gears of this unit to us. All the purchased components of this tracking system are listed as follow:

- Light Sensors \$16.80
- Electrical Components: \$88
- Charge Controller: \$36.50
- Bearings: \$40
- DC Motor: \$25

The total cost of this project turned out to be \$206.30, which is close to \$294 below our initial budget.

## Progress to Date

### Field Research

A test drive on the field took place on Thursday November 17, 2011 to get a better feeling of the cars, find out where they are mostly parked during the driver's shift, how long it takes the cars to fully charge, what components affect the batteries charge directly (e.g., A/C system), and how these cars are driven in terms of speed, and control. There are six lead-acid free batteries at 12V each in charge of energizing the motor. There is also one 12V battery designed for an auxiliary segment of the car. The batteries take 8-10 hours to fully charge, but the cars stay in plug for 14-16 hours. During the 8-hour working shift, the cars are running almost continuously. The battery sensor shows 30-60% charge at the end of the shift. Since the batteries don't run out of charge during the usage time, this allows us to use a supplementary charging source more confidently. These electric cars are used for transporting maintenance equipment and products. They

are parked outside of the buildings while loading and unloading the materials. This gives the solar panels opportunity to charge the batteries while the cars are parked. There are times that drives must enter underground parking to conduct maintenance. This definitely affects our design criteria. The solar panels must be easily adjustable that they could be flattened by the drive while going into the underground parking.

## Encountered Problems

### Energy Consumption of Initial Design

Our initial design was using linear actuators to move the solar panel, but it turns out the energy consumption was too high; it required at least 31.2W to operate. Thus, we calculated the power consumption of the single motor design, which only consumes approximately 10W. As a result, we finalized the design with the single motor implemented.

### Waterproofing Issue

In our initial design, there is a gearbox where we fit all the electrical components and gearing in so that they can be protected from dust and water. However, this design cannot guarantee the gearbox remains waterproof in rainy weather, so we decided to put the gearbox inside the car instead of having it on the roof. We need to drill a hole in the roof of the car with this design so that we can have the shaft coming out from the inside. The course instructors were really against this idea because they thought the client would never allow people drilling holes on his car, but the client was fine with this design, so we moved forward with it.

## Evaluation of Design Objectives

After conducting our field research, and doing some calculations regarding the power consumption, the design criteria for this project were decided upon. They can be summarized in the points below:

- Minimize energy consumption of the system, so that the NET output to the batteries is maximized.
  - Reduce the number of power consuming components.
- Low profile design so the electric vehicles can enter the maintenance bay

- Overall height restriction of 2.1m
- Design for use with an undetermined solar panel
  - Universal mounts
- System must be mountable on the roof of the electric vehicles (1.5m by 1.8m) and remain water-tight
  - Use of fasteners and seals such as o-rings.
- Must be able to withstand the vibrations and forces exerted by the road and weather
  - Calculate the maximum force due to wind resistance and design around this figure.

## Final Design

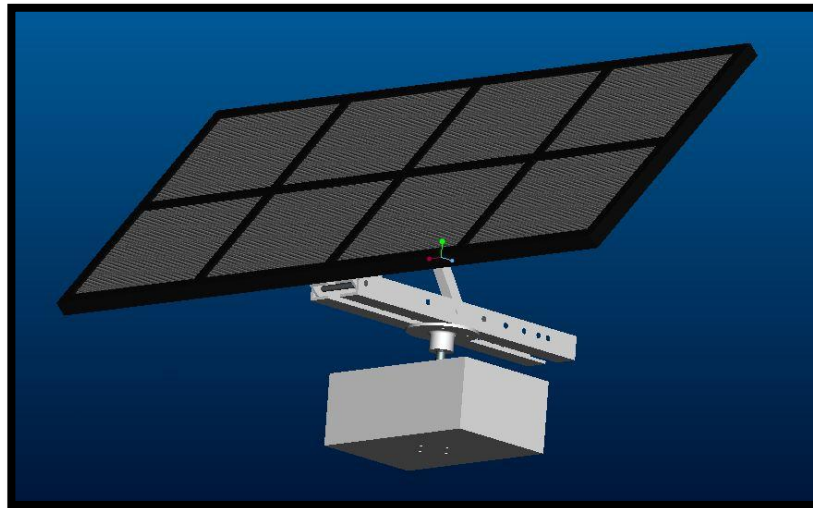

**Figure 2 - CAD model of the Finalized Design**

A description of the final design can be found in the Appendix B.

## Circuit Design

Tracking an object's motion across the sky has been the basic challenge of astronomy for centuries, and not surprisingly, some pretty clever solutions to the problem have been devised. The sun is a very bright object and can be used to actuate sensors for automatic tracking. An electric tracking system must sense if bright sunshine exists, and where in the sky the sun is physically located. With that information, the tracking system should send a signal to actuate a motor to move in the proper direction. Figure 3 shows the details of a basic solar tracking system. It consists of two photocell sensors mounted

on opposite sides of a central divider. The divider is arranged such that it can cast a shadow on the sensors, depending on the position of the sun. The tracker system sends the “Move to East” signal if the sun is in Position 1. In the same manner, if the sun is in Position 3, the tracker sends the signal “Move to the West”. Finally, the tracking system will stay stationary if the sun is in Position 2.<sup>7</sup>

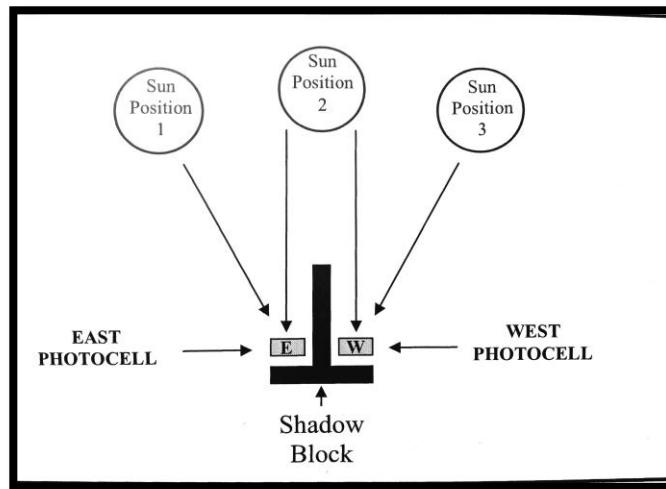

**Figure 3 – Basic Solar Tracking Principle**

A schematic diagram of the designed circuit for sensing and actuating a DC motor to follow the motion of the sun along a single axis is included in the Appendix: Figure B4. This circuit is built using 9 resistors, 2 photo sensors, 5 diodes, 2 limit switches, 1 integrated circuit comparator, and 2 miniature relays. In the circuit, the East and West photocells are each connected in series with a 1K-Ohm resistor to form voltage dividers. When either photocell is exposed to light the resistance changes, and consequently the voltage from the divider will also change. The “trigger point” for each comparator is set by the fixed voltage divider. The comparator senses the voltages from the photocells and the threshold reference to make a decision about tripping the relays.

### **Deviation from Proposal**

A redesign was required to meet these new design criteria, the main factors of which needed addressing were the power consumption and the height of the system. Our initial design required 4 linear actuators, which would require a lot of power as at least

---

<sup>7</sup> <http://www.mtmscientific.com/solartracker.html>

two of them would have to move at the same time in order to change the angle of the solar panel. This was judged to be unacceptable after the appropriate calculations were done. A reduction in the number of power consuming components was necessary. As well as the issue of power, our field research discovered a problem concerning the height of the system. It was stated earlier that our initial design was relatively tall, and with a new overall height restriction of the vehicle plus the solar tracking system set at 2.1m for the convenience of the drivers i.e. the system wouldn't have to be removed every time the vehicles needed to be maintained, something had to change. While considering both of these criteria a new design was generated. Sketches of this can be seen in the Appendix: Figure B5.

In this concept the angle of the solar panel is fixed, but can be altered manually. The main reasoning behind this is that the angle the sun makes with the ground does not change greatly throughout the day; the main variable is the direction of the car in relation to the sun as the car changes direction when moving. By having a fixed angle and a rotating element we can capture a lot more sunlight than a flat solar panel, but consume a minimum amount of energy. In Figure B2 you can see one DC motor is employed, which will drastically reduce our power consumption, and therefore maximize the output of the system to the batteries. By sinking the majority of the assembly into the roof of the car, a lot of height can be saved. This will require sealing so that the roof does not leak in rainy conditions, but this is easily achieved with the use of o-rings and etc. The inclusion of the gearbox allows us flexibility in our design. By optimizing the gear ratio through iterative calculations we can minimize the torque required by the motor, which in turn will reduce the power it consumes. A low torque system does however mean a slow system, so a balance between power consumption and speed will have to be decided upon. The angle fixing system will allow the driver to increase the angle of the solar panel throughout the year as the sun gets gradually lower in the sky, but will also allow the panel to be folded flat so that the vehicle may fit into the maintenance bay.

## **Methodology**

### **Energy Consumption**

In order to minimize the power consumption of the unit itself and to maximize the power input to the batteries, we have decided to design this system for a uni-axial tracking system. Having it designed for 2D tracking would consume more energy than the extra energy it would add to the 1D system. Having a pre-calculated optimum angle and one centered rotational motor is by far the best option available.

### **Design Dimensions**

Through the field research it was understood that there are situations where drivers must enter underground parking to perform maintenance. The height clearance of this parking facilities is 2.1m, which suggests that the driver won't be able to enter these facilities if the system is not adjustable to be completely flattened. Having an adjustable unit was our only option and led us to design a more convenient system that gives drivers the possibility of flattening the system while entering these areas.

### **Adaptable Design**

Having a business plan in mind requires designing a system that not only works the best for our current project, but also a design that could be perfectly deployed somewhere else. The idea of having a tracking solar system is suitable in many situations such as parking pay stations, street lights, payphones, traffic monitors, and much more. Designing a system that could be used in all of the above cases by making minor changes would be a great achievement.

### **Mountable and Waterproof**

The relatively small rooftops of these electric cars pose a challenge when trying to design an efficient system. Having multiple solar panels with efficiency less than 20% while staying within the allowed space requires intelligent engineering design. Having a tracking system is a prodigious step in reaching the desired efficiency while having the same number of panels. As explained before, this device is installed on the rooftop that suggests the system will be in direct contact with rainwater. Waterproofing this device is an undeniable action. It is a great appreciation that solar panels are watertight. The



remaining components and electric devices will be made water resistance by designing custom made boxes. Using waterproof sealing will also be implemented.

## **Vibration**

Taking into account the vibration and forces exerted by the road and wind is a major part of this project. Calculations have been done to ensure that no damage will occur, and that the motor has enough torque to turn against the wind resistance created by the movement of the car.

## **Perceived Problem Areas**

### **Cost vs. Performance**

High performance solar panels are essential in succeeding this project. However, this team cannot afford such good solar panels due to the limited budget. Therefore, the group was dedicated to find solar panel sponsors to counteract this problem.

### **Gears & Motor**

A gearbox is needed to protect the motor and gear from dust and rain. Also, the box should not be complicated to take off for regular lubrication and maintenance purposes.

### **Extra Weight**

The weight of the aluminum angels is a little higher than we expected because we did not want to waste money on buying materials when the shop already had something similar. This extra weight would require more torque from the motor to rotate the solar panel. So far, our current motor is still capable of handling the weight.

## **Testing**

We tested the solar tracking circuit first and then combined with the H-bridge circuit, which controls the motor. We fixed the remaining bugs and also attempt to make the solar tracking circuit as precise as possible.

We let the solar tracking panel work for a certain amount of time, and then disabled the tracking feature for the same amount of time under the same weather condition, to see the difference in net energy generated. Thus, we were able to conclude how much more energy we can save by programming the panel to track the sun.

## Deliverables

By the end of 2011-2012 academic year, we were able to produce a prototype, which will be mounted and tested on top of a UBC electric vehicle. Seven 12V batteries currently power each electric car. These batteries will be partially charged by the solar panels. Our aim is to minimize the dependency of these cars on mains electricity; however, power plugs will still be used to charge cars overnight, if necessary.

Moreover, since this project is related to UBC and SEEDS, we are asked to have a business proposal by the end of this year.

## Results

**Electricity Cost - Table 1**

City	Residential Bill Calculation					
	(KWh)	375	750	1,000	2,000	5,000
Vancouver		\$30.15	\$58.06	\$82.71	\$181.31	\$477.12
	\$/KWh	\$0.0804	\$0.0774	\$0.0827	\$0.0907	\$0.0954
	Average	\$0.0853				

**Tracking - Table 2**

Time of Year	Maximum Power generated per day, Solar tracking
	Solar Panels Used
	1
Winter Worst	0.16 Kw
Peak Sun Hours 1.47	
Summer Best	0.91 Kw
Peak Sun Hours 8.30	
Year round average	0.54 Kw
Peak Sun Hours 4.88	
\$ Saved/year	\$16.72
Peak Amps at 12v	58.50 A
System Amp rating at 12v	7.05 A

**Stationary - Table 3**

Time of Year	Maximum Power generated per day
	Solar Panels Used: 1
Winter Worst	0.14 Kw
Peak Sun Hours 1.25	0.55 Kw
Summer Best	
Peak Sun Hours 4.98	0.34 Kw
Year round average	
Peak Sun Hours 3.11	\$10.66
\$ Saved	
Peak Amps at 12v	35.10 A
System Amp rating at 12v	7.05 A

**CO2 Emission - Table 4**

	Energy kWh, Electricity Mix		CO <sub>2</sub> gramm es/kWh	CO <sub>2</sub> kg Emissions	CO <sub>2</sub> lb
Calculation of CO2 to produce electricity in KWh	3942		0.5	1.97	4.35
CO2 Emission per KWh from electricity	3942		500.0114	1971.04	4345.41
CO2 Emission, Comparison between different Energy sources	Natural Gas	3942	380	1497.96	3302.43
	Lignite brown Coal	3942	950	3744.9	8256.08
	Patent Fuel	3942	860	3390.12	7473.93

We have performed several tests and the results have been recorded in tables 2 & 3. The initial testing began with the goal of measuring how much power tracking the sun would add to the system compared to a stationary unit. In order to calculate the efficiency addition of tracking, the peak sun hours of Vancouver had to be determined for the two seasons of winter and summer, where we have the lowest and highest peak hours. These numbers would also differ due to the fact that the peak sun hours are calculated based on the reception of the solar radiations by the panels. The peak sun hours are calculated by dividing the total solar panel power for the day by 1000w. The calculated hours are included in Tables 2 & 3. Furthermore, the total power generated by the solar panel have been calculated by the following equation:

$$\text{Peak power output (W)} \times \text{peak sun hours (h)} = \text{Expected energy output (Wh)}$$

In addition, the highest current produced per day was also calculated. The results of tests performed on the unit indicate that tracking the sun would add close to 30% in total power generated by the solar panel.

In order to determine how much money we would save per year by using this tracking solar panel, we had to determine how much does electricity cost in BC. Vancouver has the lowest electricity price per KWh among all the Canadian cities. However, the price of electricity per KWh depends on the power usage. We have included the price/KWh for different KWh ranges in TABLE 1. The average price per KWh has been determined to be \$0.0853. This would suggest that we would be saving a total of \$16.72 per year per solar panel. For the total of 20 solar panels required for the twenty electric cars available at UBC, this would be a total saving of \$334.4.

We have also calculated the total carbon emission reduction potential by using these solar panels as an alternative energy source for charging the twenty electric cars available at UBC's car fleet. The CO<sub>2</sub> emission has been calculated for both production and consumption of the total power generated by the solar panels. A total of 1,973.01 Kg of CO<sub>2</sub> emissions are reduced from production and consumption of electricity from conventional energy sources. In addition, we have calculated the carbon emission for three different energy sources such as natural gas, lignite brown coal, and patent fuel.

## **Future Recommendation**

### **Precise System Control**

Though a high-torque-high-speed motor was selected, its RPM is still a bit higher than expected, which causes the system to over rotate sometimes. The motor needs to rotate in the reverse direction to point the solar panel back towards the sun. As a result, there is sometimes oscillation in the system. A PWM circuit should be integrated with the current circuit to control the system more precisely to prevent oscillations as the future recommendation.

## Gantt Chart

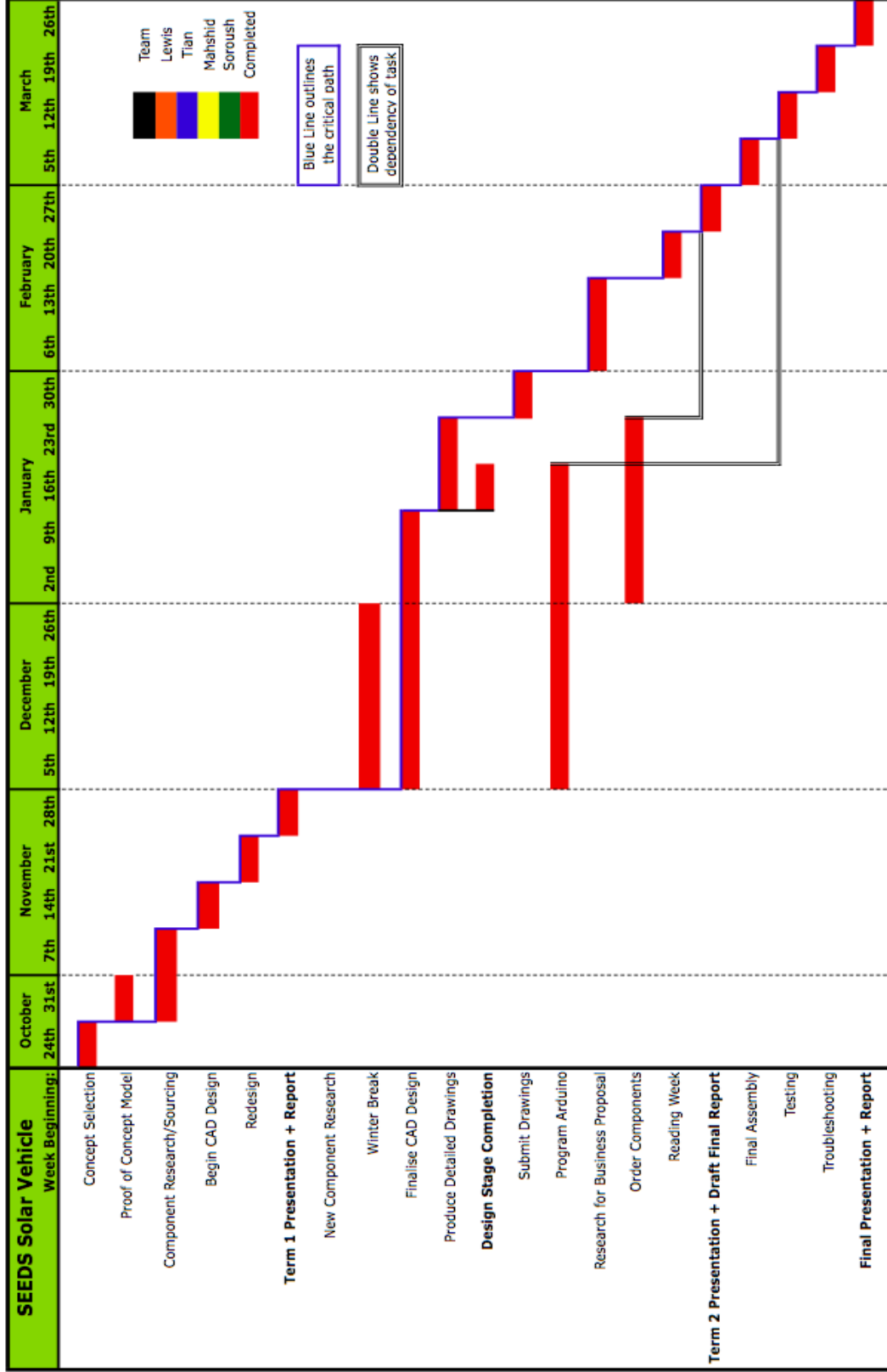

## Conclusion

As the world is facing climate change and global warming due to human activities, more innovation and research has been done into unconventional energy sources to reduce the environmental impact of human activities such as using/burning fossil fuel. As part of this “Green” movement, UBC is making strong and effective steps towards sustainability. As a leader in sustainability, UBC is taking any action possible to achieve its goal to minimize carbon emissions. SEEDS Solar Vehicle is a small part of this large movement. UBC’s on-campus vehicles are being charged by mains electricity (110V), which is generated by burning fossil fuels and UBC currently has a fleet of 20 electric cars. Our mission is to minimize UBC’s electric vehicles dependency on mains electricity and use solar panels to charge them. Most of the solar panels have a fixed position at a certain angle towards the sky; thus, the power output from the photovoltaic cells is greatly decreased as the intensity of solar radiation upon the solar panels varies during the day. In order to maximize the photovoltaic cell’s power output, light sensors are to be used to detect the angle of maximum solar radiation. Solar panels are to be integrated with this solar tracking system which will move the panel in such a way that direct sunlight is always incident with the PV cells to ensure maximum power output and will maximize efficiency of this energy source.

We have designed and manufacture an automated solar panel frame that can move with the direction of sunlight that will be mounted on top of UBC’s electric vehicles to charge their batteries using the solar energy. This project has the potential to be commercialized, and our goal is to produce the best prototype design.



## Appendix A – Calculations

### A.1 - Basic Calculations

#### New Design with Aluminum Angle

Length of Aluminum Angle	0.7m
Width of Aluminum Angle	0.05m+0.04m
Thickness of Aluminum Angle	0.006m

Total Al frame volume:  $4*[0.7*0.006*(0.04+0.05)] = 4*0.000378 = 0.001512 \text{ m}^3$

Total Al frame weight: volume \* density =  $0.001512 * 2.7 * 10^3 = 4.0824 \text{ kg}$

However, there are holes on the aluminum angles, it will reduce the weight to about 4 kg.

### A.2 - Solar Intensity

Solar constant=  $1367.7 \text{ W/m}^2$

Area of the earth=  $127,400,000 \text{ km}^2$

Solar power received by earth=  $1367.7 \text{ [W/m}^2] * 127,400,000 \text{ [km}^2] * (1000^2) \text{ [m}^2/\text{km}^2] = 1.742*10^{17}$

### A.3 – Wind Resistance

$$F_d = \left(\frac{1}{2}\right) \rho v^2 C_d A$$

$$\rho = 1.293 \text{ [kg/m}^3]$$

$$v = 8.33 \text{ [m/s]}$$

$$C_d = 1.28 \text{ (Flat plate perpendicular to flow)}$$

$$A = 1.056 \text{ [m}^2]$$

$$\rightarrow F_d = 60.6 \text{ [N]}$$

#### A.4 – Motor Selection

$$M = 0.5 \mu P d$$

M = Friction Moment [Nmm]

$\mu$  = Coefficient of Friction

P = Load [N]

d = Bore diameter [mm]

Thrust Bearing:  $M = 0.5 * 0.0013 * 157 * 20 = \mathbf{2.041 \text{ Nmm}}$

Deep Groove Ball Bearing:  $M = 0.5 * 0.0015 * 100 * 20 = \mathbf{1.5 \text{ Nmm}}$

Total M = 3.541 Nmm = 0.003541 Nm = 0.5 oz-in

The force acting point is 2.25 inch, which is 0.057m away from the center.

$$M = 16\text{Kg} * 0.057\text{m} * 9.8\text{m/s/s} = 8.9376 \text{ Nm}$$

RPM = 30

$$M = (60 * P) / (2\pi * \text{RPM})$$

$$P = 8.9376 * 2\pi * 20 / 60 = 18.71 \text{ W}$$

The voltage is 12V,

$$I = P / V,$$

Thus the current should be greater than 1.5 amps.

Finally, the 20RMP, 2 amps motor was selected.

## Appendix B – Figures & Sketches

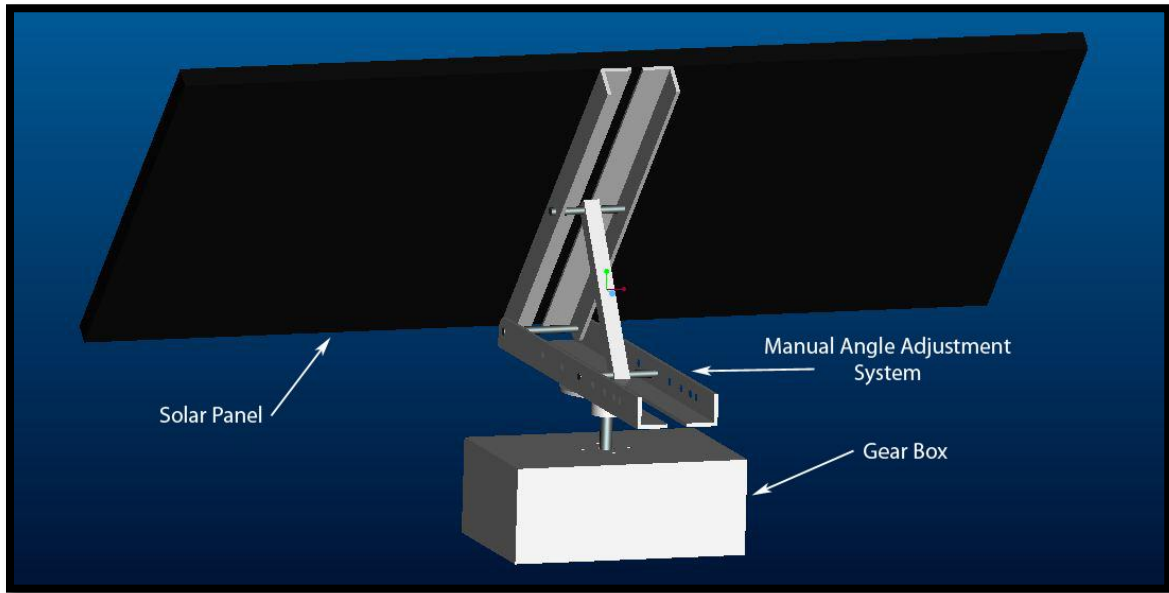

Figure B1 - CAD model indicating main parts

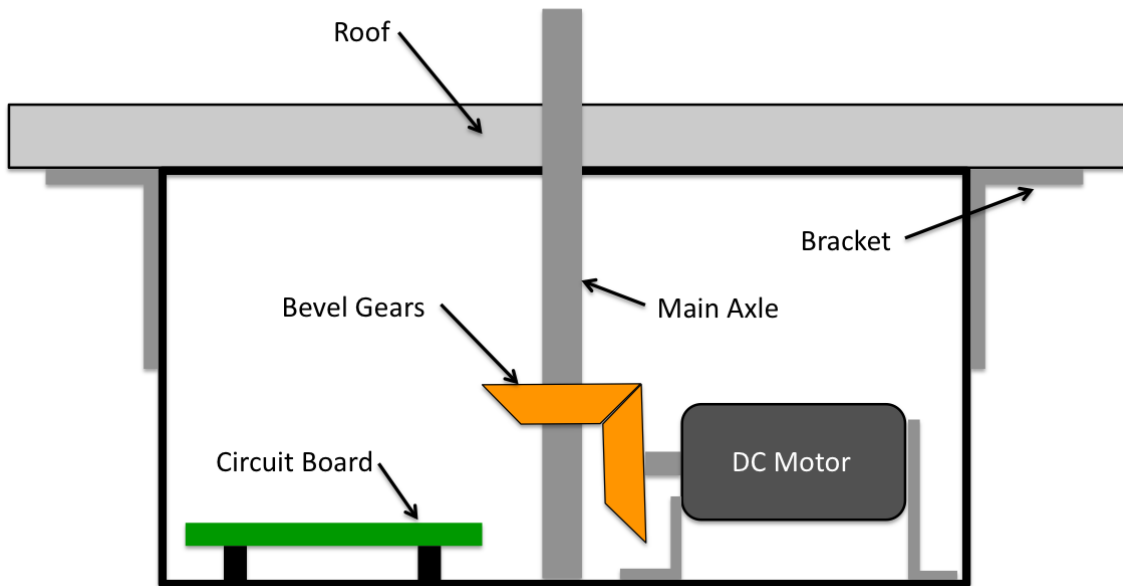
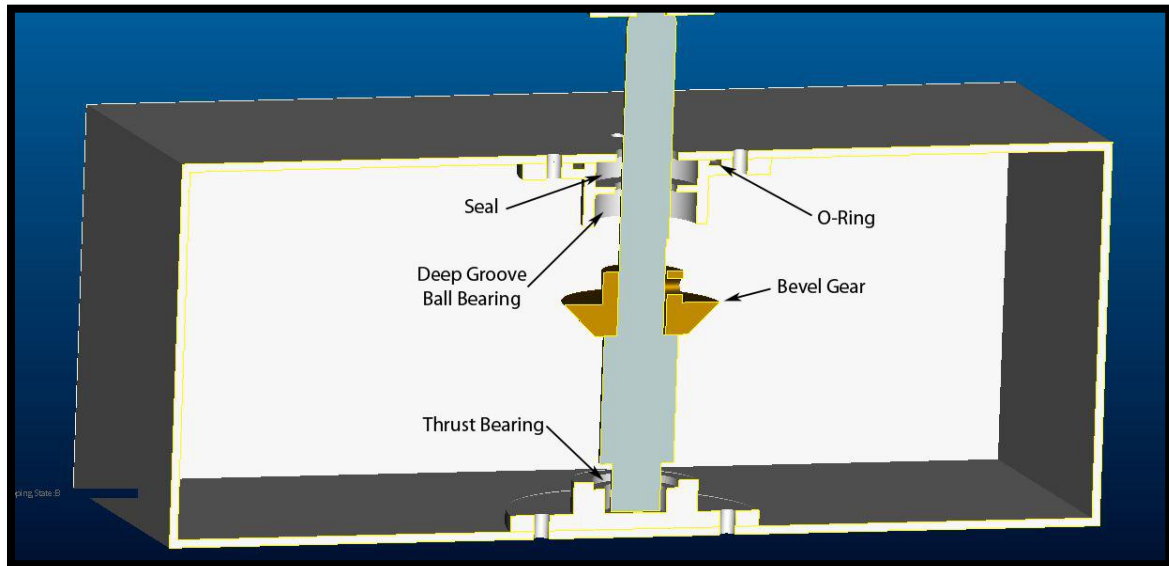

Figure B2 - Diagram of the internal layout of the gearbox



**Figure B3 - CAD model showing internal detail of the gearbox**

As you can see from Figure B1, the solar tracker consists of three main parts: the solar panel itself, the adjustable frame, and the gearbox. The solar panel is mounted onto the frame using pre-existing bolting points. The angle of said solar panel can then be adjusted by removing the cross peg from the horizontal frame section then aligning the prop bar with another pair of holes and replacing the cross peg. On the holes are indicated the month of the year in which that particular angle should be used. The gearbox will house the DC motor, the gearing system, and the circuit board. This layout has been outlined in Figure B2. It is also evident in this figure how the system is to be mounted. As you can see, the gearbox is mounted internally to the roof by brackets. This is to protect it from the external weather conditions, and also reduces the overall height of the system significantly. Both of these statements are in line with our design objectives stated earlier.

Now, for a more detailed look into the design of the gearbox. Looking at Figure B3 you will see 4 main pieces: the main axle, upper and lower bearing housings, and the bevel gear. The main axle is stepped and is chamfered in order to locate accurately the bearings, seals and frame that will all attach to it. It also has flats so that positive connection between the axle, the bevel gears, and the frame can be made with the use of setscrews. It is visible in the cross-section of the bevel gear where this connection

occurs. The lower bearing housing will house the thrust bearing. This will take the entire axial load from the system, which includes the weight and the wind force on the solar panel. The upper bearing housing will house a deep groove ball-bearing which will take any radial loads due to weight and wind force. It will also house a radial seal and an o-ring to prevent any external water from entering the gearbox.

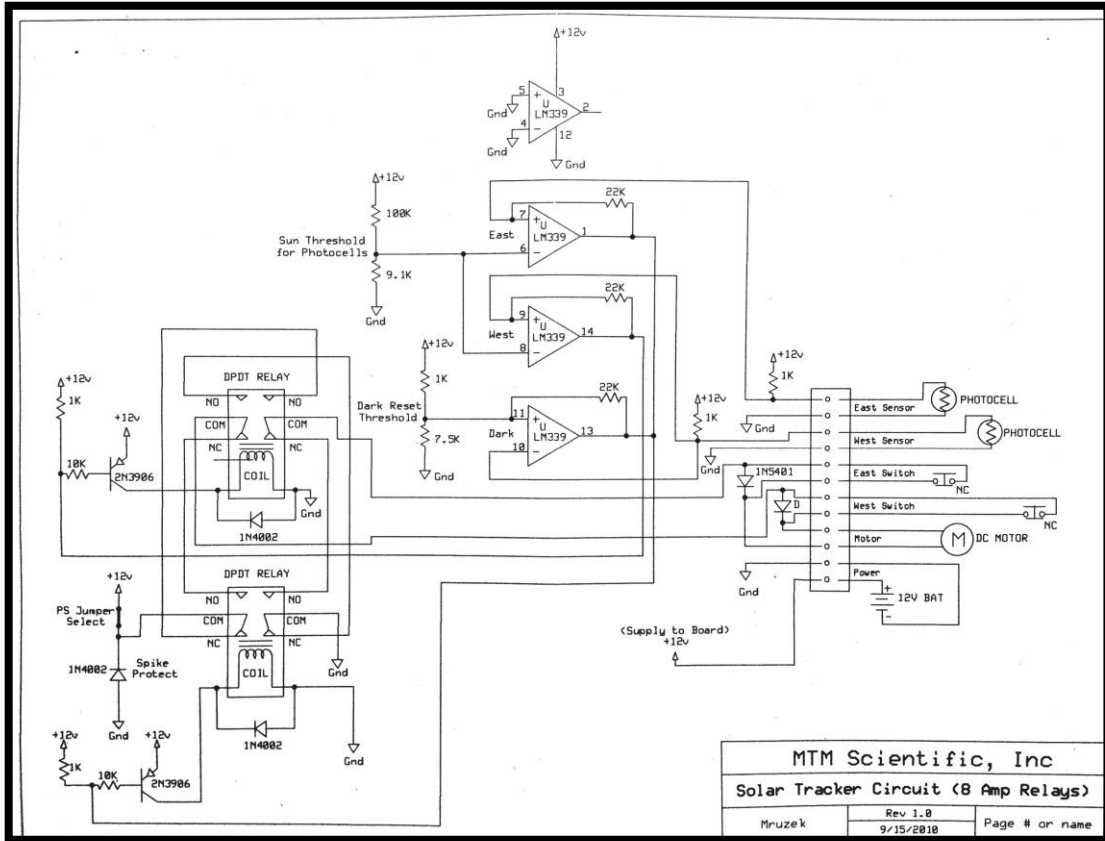
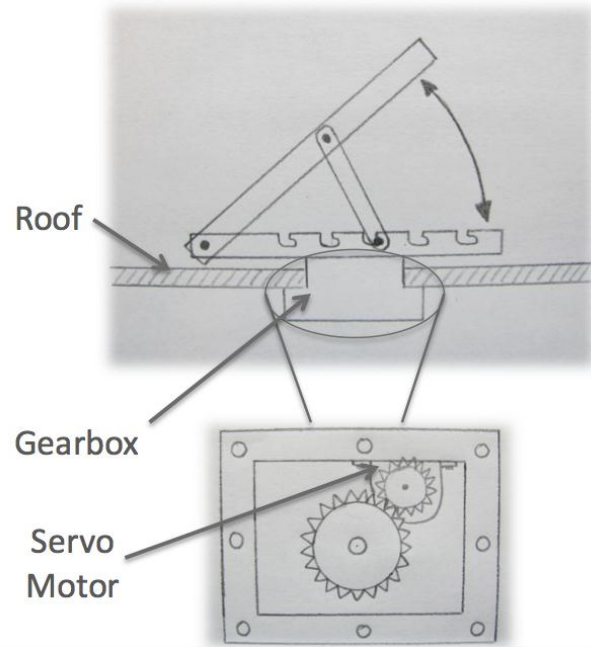

Figure B4 – Schematic of Circuit



**Figure B5 - Initial sketch of Final Design**